

www.multiwayrobotic.com

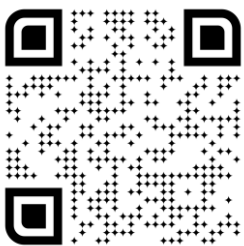
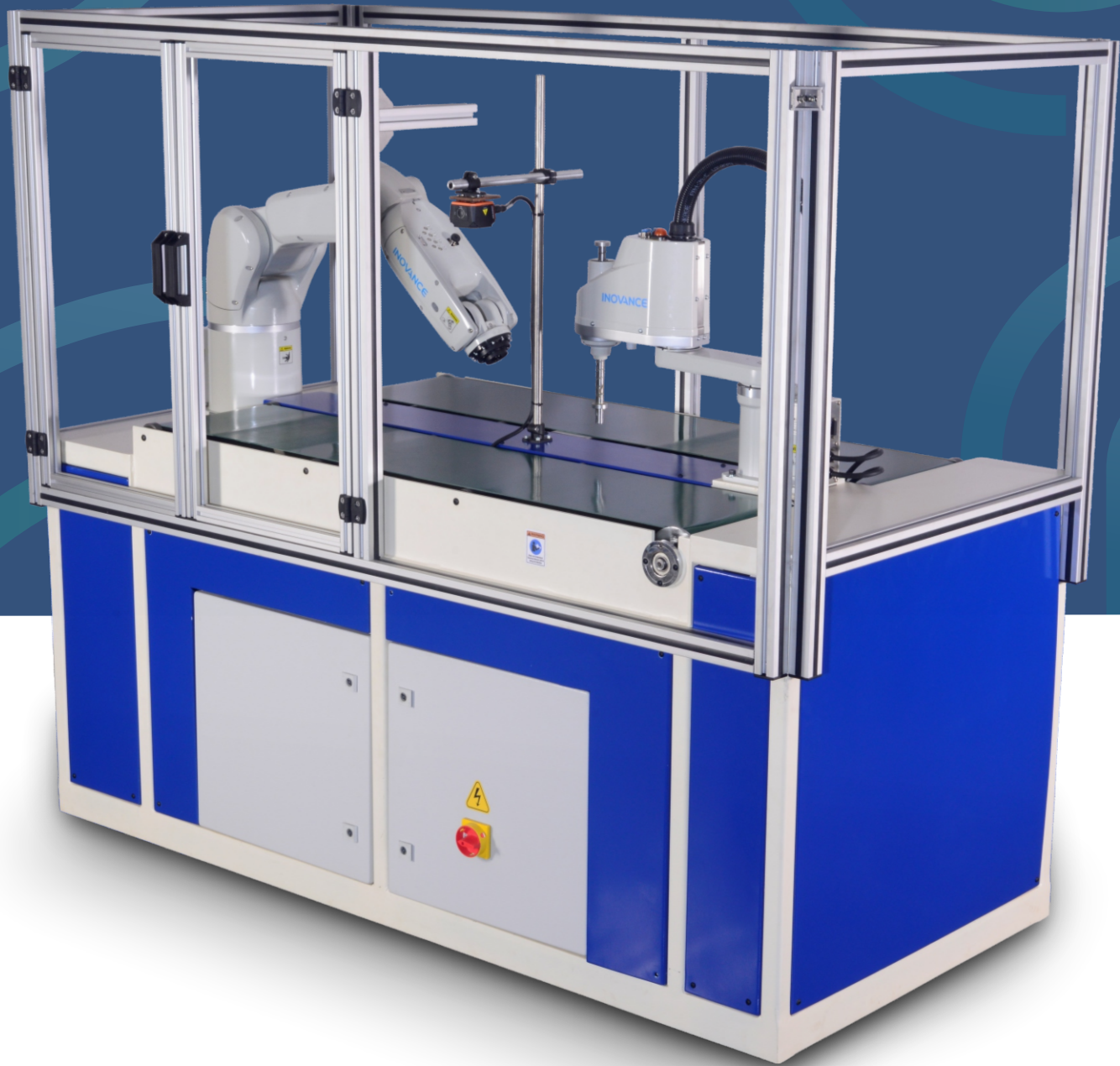

PERFECTLY
INTEGRATED AUTOMATION

INDUSTRIAL ROBOT & SCARA

- Packing
- Pick & Place
- Stacking, Material Handling
- Sorting
- Palletizing



BAG FILLING & SEWING PACKAGING MACHINE

- Automated Bag Feeding System
 - Multi-application Bag Filling System
 - Automatic Bag Sewing System
 - Equipped With State Of Art Technology
-
- Optional Checkweigher
 - Optional Safety Integration
 - Optional Robotic Palletizing System



INDUSTRIAL AUTOMATION & CONTROL

- UL 508A Industrial Control Panel
- PLC, HMI Programming
- Supervisory Control and Data Acquisition (SCADA) development & Modification
- Data collection and operational reporting
- Field Start-up & commissioning services
- Control system Network structure Design
- Submittal & engineering drawing review
- Total Automation & Robotics System integration
- OPC/IIOT integration



PACKAGING MACHINES

- Center Seal & Three Side Seal Pouch Making Machine
- Veterinary Hand Gloves Making Machine
- Dunnage Bag Making Machine
- Garbage Bag Roll Making Machine
- Side Seal Bag Making Machine
- Weighing Conveyor
- Zipper Bag Making Machine
- Two Color Flexo Printing Machine
- Slitter Rewinder Machine

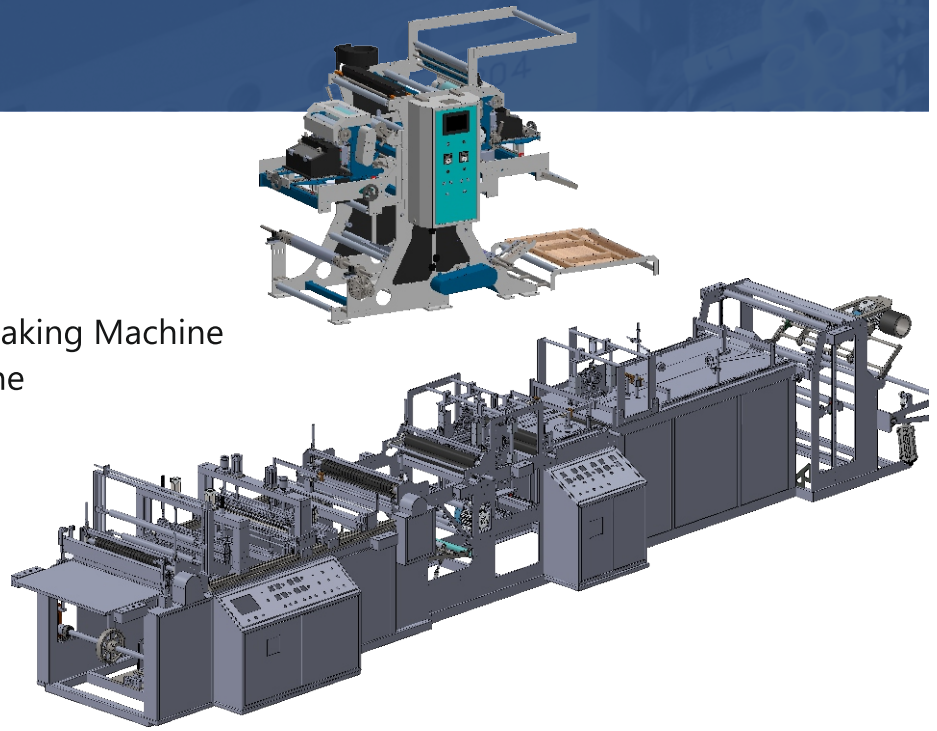





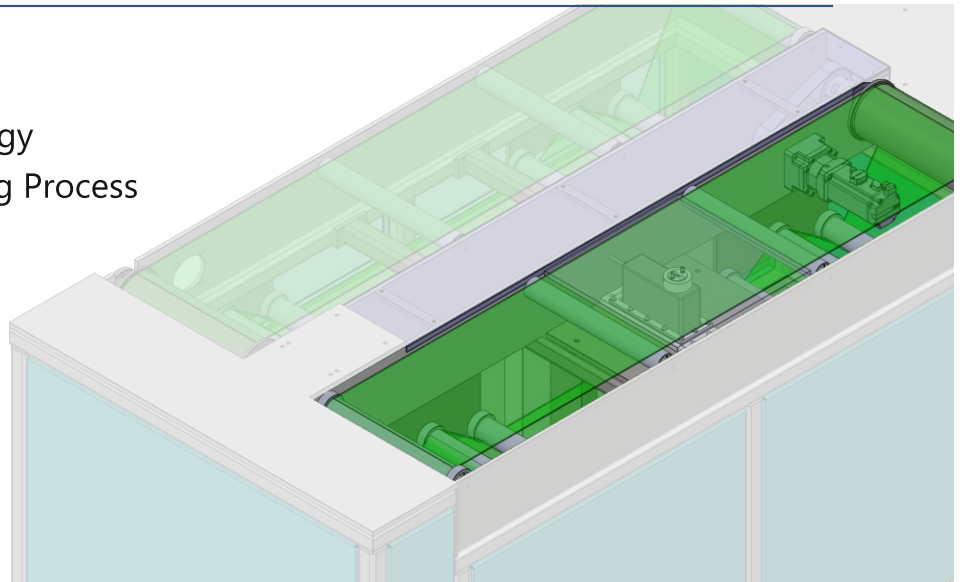



CHECKWEIGHER

- Equipped with State of Art Technology
- Customized to Integrate into Existing Process
- Rugged and Modular Structure
- Optimal Accuracy in Weighing
- Available with Robot Integration

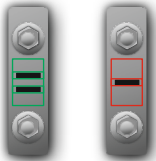
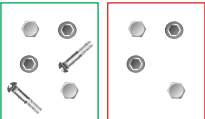

VISION SYSTEM

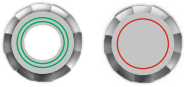
 Measurement	 Existence	 Recognition	 Location	 Count	 Defect Detection	 Logic
 OK / NG Edge Count	 6 / 4 Spot Count	 OK / NG Code Recognition	 OK / NG Circle Existence			



PALLETIZING SOLUTIONS

Integrate to Existing Process

Palletizing Height upto 2100 mm with Lifting Column

Rapid Deployment

Mobile And Flexible

Easy To Use

Safe And Reliable

Consistent Accuracy

Enhanced Efficiency



50 Alberigi Dr, Suite 104
jessup, PA 18434

p | 866.888.2510

e | sales@multiwaycontrol.com

w | www.multiwaycontrol.com

w | www.mutiwayrobotic.com